



**MAINLINE**

Preferred by the pros.™

MAINLINE®

**ProVersa**

Tub & Shower Rough-in valve(2-Way)

**SPECIFICATIONS**

**Features**



- Pro versa Tub & Shower **Rough-in valve(2-way)** w/integral stops
- Pressure Balance Valve with **built-in diverter function (Non-Share)**
- **Function Limiter included to reduce to Single Function**
- Pro-Versa Ceramic Disc Cartridge (Included with the Mainline 611 Series trim)
- Includes Plaster Guard and Pressure-Test Cap
- Flow Rate : 26.5 LPM/7.0 GPM at 60 psi
- Brass Construction
- 1/2"-14 NPT Connection
- With Check Valve
- Adjustable temperature limit stop to control maximum hot water
- Suited for standard Back-to-back and thin wall installation
- Easy-to-access mounting system (Hardware included)
- 100% Factory Tested



MAINLINE®  
**ProVersa**

NSF/ANSI 372  
NSF/ANSI 61-9



M420

**Add-on Components**

		
MSRI-PA Rough-in valve adapter PEX-A For cold Expansion Pex Pipes	MSRI-PB Rough-in valve adapter PEX-B For CrimpPex Pipes	MRIV-EXT Rough-in Valve Deep Wall Installation Kit

Please visit [www.mainlinecollection.ca](http://www.mainlinecollection.ca) for available finishes. Finish is defined by additional suffix.

Specified model meets or exceeds the following:

- ASME A112.18.1/CSA B125.1
- IAPMO/cUPC

**AVAILABLE MODELS**

M410 – Tub & Shower Rough-in Valve

Mainline products have been manufactured under the highest standards of quality and workmanship. That is why we offer "Limited Lifetime" warranty on the function and finish of our rough-in valves.



**Drawings**

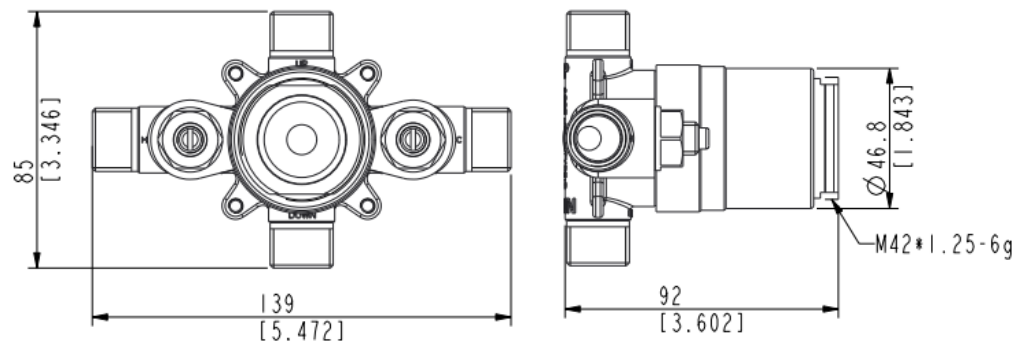

**SUBMITTAL INFORMATION**

Name: \_\_\_\_\_ Contractor: \_\_\_\_\_

Location: \_\_\_\_\_ Contact #: \_\_\_\_\_

Notes: \_\_\_\_\_

**Service & Parts**

Please reach out to [epleservice@emcoltd.com](mailto:epleservice@emcoltd.com) for support/ visit [mainlinecollection.ca](http://mainlinecollection.ca) / CANADA +1 (450) 621 5636