

# Push Connect® Brass 90 Degree Elbows

Product Specifications

Page 1 of 2

## PRODUCT FEATURES

- Forged Lead Free\* Brass
- Maximum Working Pressure: 200 PSI
- Maximum Temperature Rating: 200° F
- Compatible with Copper, CPVC, PEX & PE-RT
- Replaceable O-Ring Seal Design
- Removable and Reusable
- Push to Connect
- Full Flow
- Pre-Inserted Stiffener



## APPROVED APPLICATIONS

- Plumbing
- Heating
- Irrigation
- Underground
- Hydronic Heating
- Behind Walls without Access Panel

*NOTE: When using PEX, a tube stiffener should be inserted into the PEX tubing end prior to insertion into the fitting.*

Push to connect fittings install in seconds, never requiring glue, crimping or soldering. Fittings connect COPPER, PEX and CPVC, PE-RT quickly and effortlessly, making quick work of every plumbing project, ensuring a permanent leak-free seal every time.

✓ To Submit	Part #	Size
	MLPFB312	1/2" x 1/2"
	MLPFB334	3/4" x 3/4"
	MLPFB301	1" x 1"

## FORCES FOR MECHANICAL SEPARATION TEST

Nominal Size		Longitudinal (Pull) Test	
Inches	mm	Lbf	N
1/2	13	150	667
3/4	19	275	1223.2
1	25	475	2112.8

## Warranty

See warranty information for more details.

All dimensions listed are nominal. MAINLINE® reserves the right to make product and material changes at any time without notice.



\*≤ .25% Pb

**Contact your sales representative for more information or visit our website at [mainlinecollection.com](http://mainlinecollection.com)**

# Push Connect® Brass 90 Degree Elbows

Product Specifications

Page 2 of 2

## MATERIALS & SPECIFICATIONS

#	Component	Material (< = 1")
1	Body	Lead Free Brass
2	O-Ring Seal	EPDM70
3	Support Ring	PA66
4	Grip Ring	Stainless Steel
5	Push Ring	POM
6	Seat Ring	POM
7	Bushing	PSU

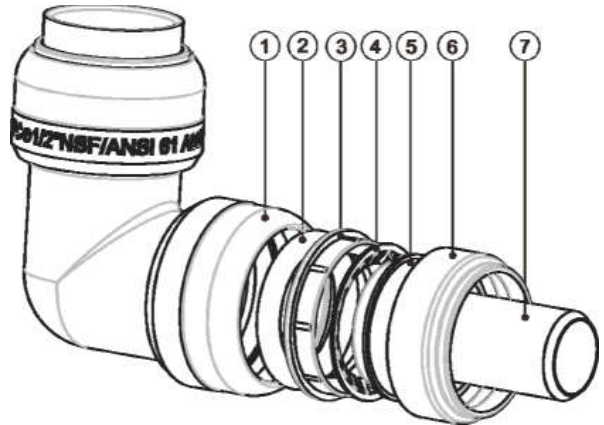

## DIMENSIONS

#	Ø	D	L
MLPFB312	0.64	0.97	1.44
MLPFB334	0.88	1.11	1.71
MLPFB301	1.14	1.21	1.86

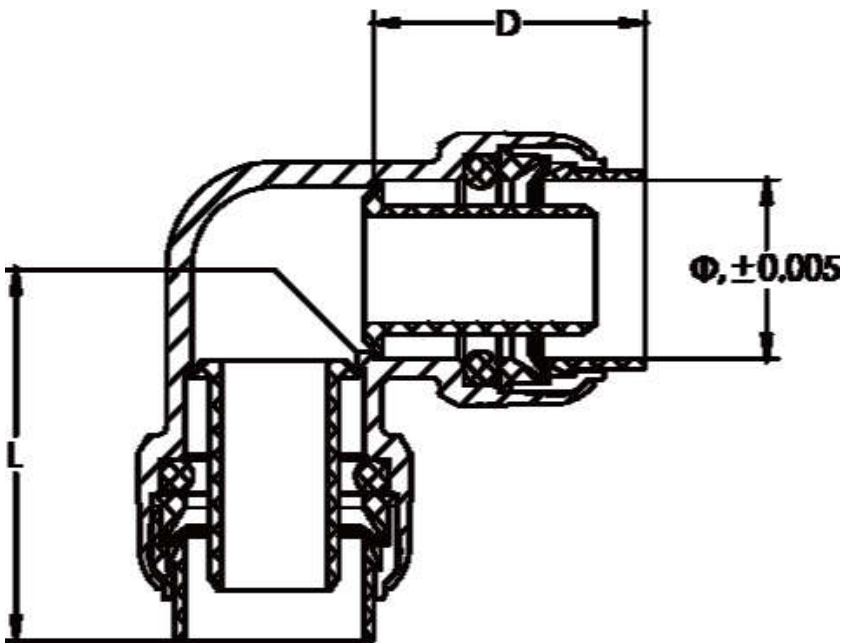

Contact your sales representative for more information or visit our website at [mainlinecollection.com](http://mainlinecollection.com)