

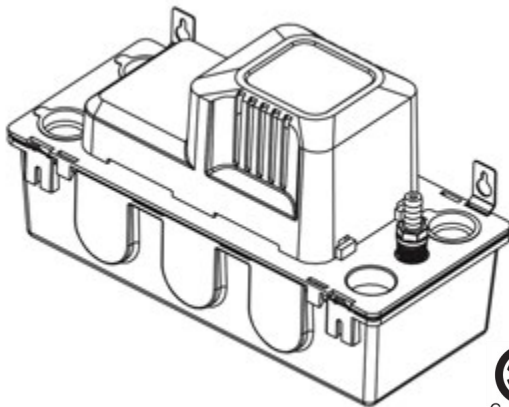

**INSTALLATION &
OPERATION MANUAL**

CONDENSATE PUMP

MODELS: MLP77150, MLP77152, MLP77202



Safety Guidelines

Carefully read, understand and follow all safety instructions in this manual.

 This is the safety alert symbol. When you see this symbol, look for one of the following signal words.

⚠ DANGER Indicates a hazardous situation which, if not avoided, will result in death or serious injury.

⚠ WARNING Indicates a hazardous situation which, if not avoided, could result in death or serious injury.

⚠ CAUTION Indicates a hazardous situation which, if not avoided, could result in minor or moderate injury.

Safety Information

⚠ DANGER Risk of death, serious personal injury, or property damage due to electric shock, explosion or fire.

- RISK OF ELECTRICAL SHOCK. Disconnect and lockout power supply before removing existing pump or installing or servicing this pump.
- RISK OF ELECTRICAL SHOCK. This pump is supplied with a grounding conductor and grounding type attachment plug. To reduce the risk of electric shock, be certain that it is connected only to a properly grounded, grounding type receptacle. For added safety, it is highly recommended to connect this pump to a GFCI (Ground Fault Circuit Interrupter) outlet.
- Do not use this pump to pump flammable or explosive fluids such as gasoline, kerosene, etc. Do not use this pump in flammable or explosive environments. Use only with liquids compatible with the pump component materials.
- Do not install this pump in any location classified as hazardous by the National Electrical Code, ANSI/NFPA70.
- Do not handle this pump with wet hands or while standing on wet or damp surfaces or in water. Fatal electric shock can occur.
- When this pump is in use, do not touch the motor, piping or water until power is disconnected to the unit. If the power source (disconnect) is not within sight, lock it in the open position and tag it to prevent unintended application of power. If the power source is not accessible, contact the electric utility company or an electrician to have the power disconnected.

⚠ WARNING Risk of, severe personal injury or death due to electric shock or fire

- To reduce the risk of fatal electric shock, always disconnect the power supply before installing or servicing this pump.
- This pump must be connected to a properly grounded electrical outlet. The use of a GFCI (Ground Fault Circuit Interrupter) is highly recommended and may be required by local code.
- The installation of this pump must be in accordance with the National Electric Code (NEC), Uniform Plumbing Code (UPC), International Plumbing Code (IPC) as well as all applicable local codes and ordinances. Check all code requirements before installing this pump.
- This pump is supplied with a grounding conductor and grounding type attachment plug. DO NOT remove the grounding prong from the plug. Failure to properly ground the pump, can cause portions of the pump to become energized.

Safety Information (continued)

⚠ WARNING Risk of severe personal injury or death due to electric shock, or fire.

- Do not handle this pump with wet hands or while standing on wet or damp surfaces or in water. Fatal electric shock could occur.
- The motor is equipped with an automatic resetting thermal protector and if overheating occurs may restart unexpectedly.
- Do not use this pump for potable/drinking water or with other liquids not compatible with the pump. Use only in applications for which the pump is designed for.
- Do not lift or carry the pump by the power cord. This could cause damage to the cord and expose the live conductors inside the cord. Fatal electric shock could occur.
- The electrical supply must be located within reach of the power cord. DO NOT use an extension cord to power this pump.
- Only use a replacement power cord that is the same length and type as originally installed on the pump. The use of an incorrect cord may exceed the electrical rating of the cord and could result in death from electric shock, serious injury or equipment failure.
- Do not modify the power cord in any way with exception of connecting it to a control panel or junction box. Any splice in the cord, must be made within a junction box that complies with all electric codes.
- Do not modify any part of the pump. Any modification could affect the operation of the pump and cause damage to the pump, equipment or property.
- CALIFORNIA PROPOSITION 65 - This product contains chemicals, including vinyl chloride, which is known to the State of California to cause cancer, birth defects and reproductive harm. For more information go to www.p65warnings.ca.gov.

⚠ CAUTION Risk of personal injury, electric shock or equipment or property damage.

- Do not remove any warning tags or product information labels from the pump or cord. Warranty will be voided if tags or labels are removed.
- This pump and equipment that it is used with may start automatically. Lockout and tag power supply before attempting service on this pump.
- Proper operation of this pump requires detailed installation and operation instructions. Do not allow unqualified persons to handle, install or operate this pump or the equipment it connects to.
- Wear proper protective equipment when installing and servicing this pump. This includes, but not limited to, safety glasses, safety gloves and dielectric rubber boots.
- Do not allow children to play with this pump or in the area where the pump is installed.
- Keep area in which the pump is installed clean and uncluttered.
- Do not allow pump to freeze or operate in freezing conditions. Damage to the pump, equipment and property may occur.
- This pump is not rated for plenum use. Do not install inside a plenum.
- Some models are equipped with a high level safety switch (See page 4). These models will have 2 low voltage wire leads coming from the motor housing. Do not mistake these for high voltage leads as damage to the switch and/or equipment will occur. Connect the safety switch wire leads to a Class II low voltage circuit only.

Description

This automatic condensate pump is designed to remove condensate water that drains from air conditioning evaporator coils, refrigeration coils, dehumidifiers, condensing furnaces, boilers and tankless hot water heaters. All models include a 3/8" barbed discharge fitting with built in check valve and four 1-1/8" inlet openings. The tank capacity is .5 gallons. All models include a 6' power cord with molded 3 prong plug. The maximum water temperature rating is 140°F (60°C)

Specifications

Model	HP	Volts	Amps	Hz	Watts	Discharge Size	Safety Switch Included	Max flow GPH	Max Head Ft. (Max PSI)
MLP77150	1/50	115	1.2	60	65	3/8"	No	88	18' (7.8)
MLP77152	1/50	115	1.2	60	65	3/8"	Yes	88	18' (7.8)
MLP77202	1/30	115	1.5	60	80	3/8"	Yes	108	21' (9.0)

Dimensions

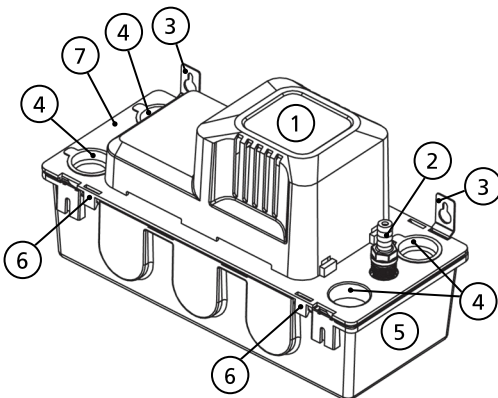
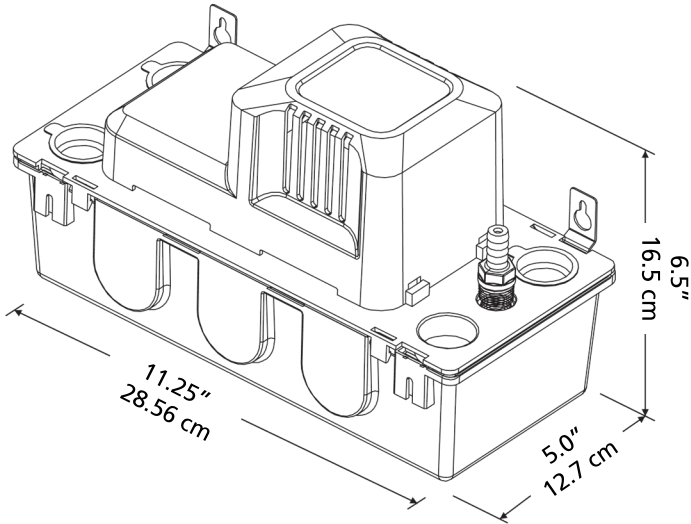

Component Overview

1. Motor Cover
2. Discharge fitting
3. Wall mount tab (2)
4. Inlet (4)
5. Tank
6. Release tab (4)
7. Upper pump housing

Installation

Installation Options

1. **Floor mount.** Install the pump on a flat level surface on the floor. For proper operation, ensure the pump is level and the surface can support the weight of the pump.
2. **Wall Mount.** Insert the included mounting tabs into the slots on the pump tank until they lock in place. See Figure 1. The tabs can be attached to either side of the pump for easy installation. The space between the mounting tabs is 9-1/8".

NOTE: If required, the upper pump housing can be rotated 180° to provide alternate access to the discharge outlet, safety switch or power connection. To remove the upper housing, gently pull outward and lift up on the 4 release tabs that secure the housing to the tank. To re-attach, line up the tabs to the notches on the tank and gently push until the housing snaps into place. Make sure the pump is level after mounting. Mount the pump below the condensate pan drain.

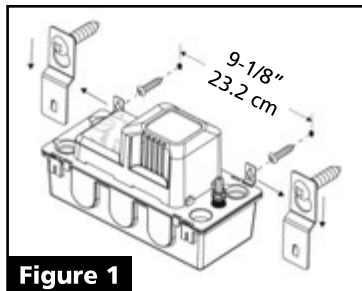

Figure 1

NOTICE! A condensate neutralizer may be required by some codes to keep the pH of the condensate within an acceptable range for discharge into drains. If required, follow instructions that came with the neutralizer.

Piping / Tubing Connections

Inlet Piping/Tubing (sold separately)

1. Cut the end of the inlet pipe(s) or tubing at a 45° angle to prevent blockage with the bottom of the tank. See Figure 2.
2. Connect the drain pipe/tubing from the appliance to the one of the 4 inlet openings on the pump. Install the pipe(s) into the inlet openings making sure the pipe extends into the tank by at least 1". Ensure that the piping/tubing will not interfere with the float ball operation. Cover any unused inlet openings using the plugs included with the pump. Make sure that inflow will not exceed the rated output of the pump.

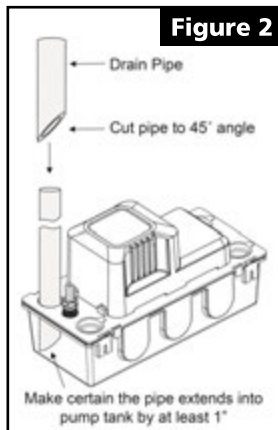

Figure 2

Discharge Tubing

1. Attach 3/8" ID tubing not included to the barbed discharge fitting/check valve. Secure with a hose clamp.
2. Extend the tubing straight up from the pump making sure not to exceed the total head capacity of the pump. It is recommended not to exceed 80% of the head capacity of the pump to ensure proper operation.
3. For optimum performance, slope the outlet tubing from the highest point slightly downward towards a drain. If it isn't possible to direct the discharge in a continuous downward slope, make an inverted "U" trap above the pump at the highest point. See Figure 3.

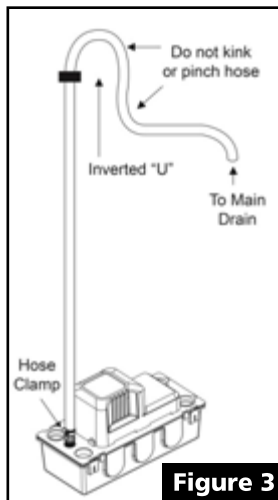

Figure 3

Piping / Tubing Connections (continued)

NOTE: The barb fitting may be removed for cleaning or alternate installations. When re-attaching, hand tighten only as overtightening may cause the housing to crack. The thread size of the discharge port is 3/8" NPT.

4. Secure the discharge line to prevent movement which could cause a malfunction.

Electrical Connections

General Guidelines

- The power supply voltage must match the voltage specified on the pump nameplate.
- The pump should be connected to a dedicated circuit with no other equipment in the circuit.
- Ensure the circuit breaker / fuse is of adequate capacity for the circuit/pump.

High Level Safety Switch (certain models only, see page 4)

NOTICE! The safety switch should be connected to a Class 2 low voltage circuit (not to exceed 30 volts, 1A). If included with your pump, it is highly recommended to use this feature to prevent damage from condensate overflow in the event of power outage, pump failure or blocked discharge. The safety switch can be configured to shut down the appliance in the event of an overflow situation. The switch can also be configured to be connected to an external alarm or relay, (not included).

****Please read carefully!****

NOTICE! The safety switch is configured in such a way that reverses the normal operation of NC (normally closed) and NO (normally open) terminals (see Figure 4). The switch comes from the factory wired to the NO and COM terminals. This configuration will open a circuit to shut down the condensing unit, furnace or thermostat. See Figures 5, 6 & 7 on page 7 for common wiring options. **Your installation may vary. Make sure you follow the instructions for your thermostat and/or appliance. Consult an electrician or HVAC technician if unsure.**

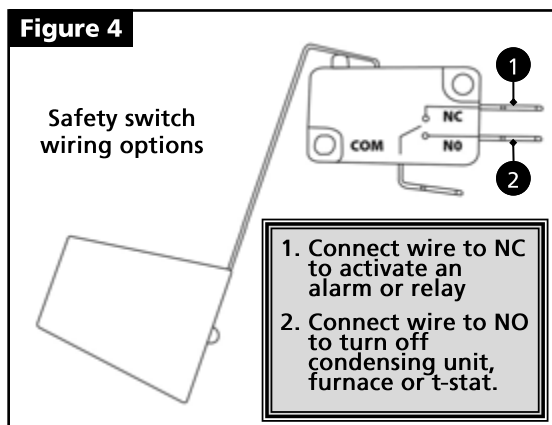

Alarm / Relay connections

The safety switch may also be configured to close a circuit to activate an external alarm or relay (not included) by moving the lead wire from the NO to the NC terminal.

To change the wiring configuration, remove the screw that secures the motor cover to the upper housing. Gently slide the cover towards the discharge fitting to release it from the locking tabs. Lift the cover off and locate the safety switch. While supporting the switch, remove the lead wire from the NO terminal and attach it to the NC terminal.

Electrical Connections (continued)

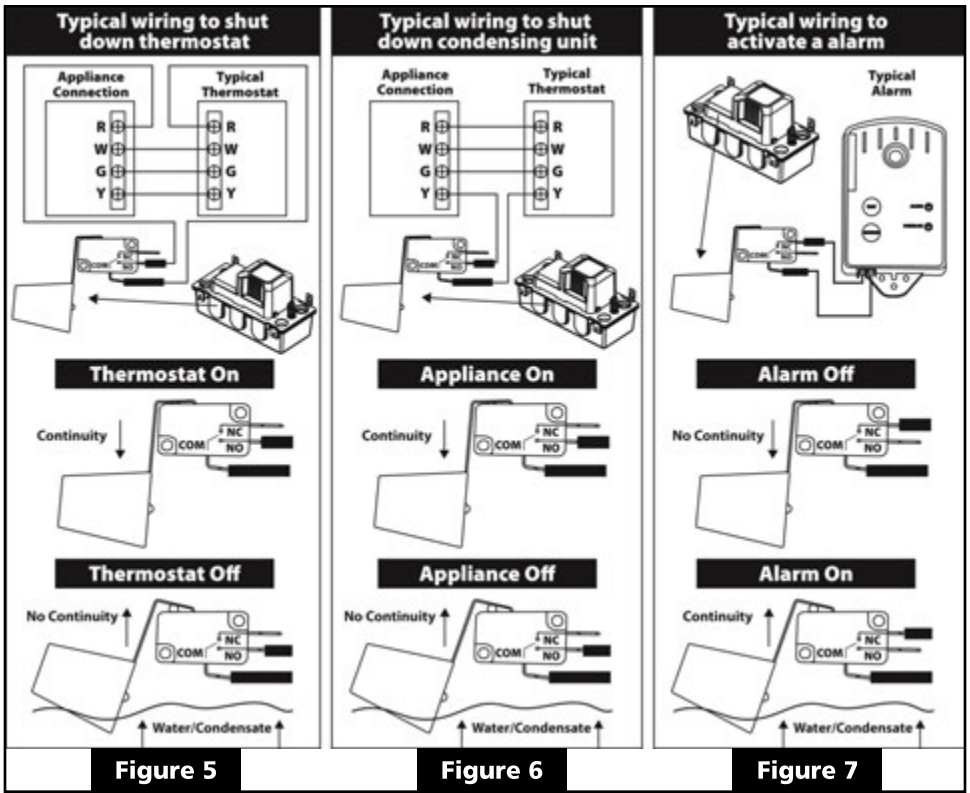

115 Volt Models with supplied power cord & 115 volt plug

- Connect the plug end of the power cord to a properly grounded 115 volt outlet (Figure 8). The use of a GFCI (ground fault circuit interrupter) is highly recommended and may be required by local codes.
- The electrical supply must be within reach of the power cord. DO NOT use an extension cord with this pump.

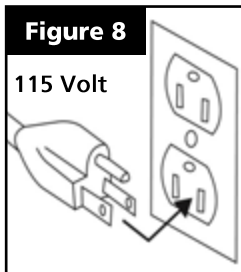

Testing Installation

- To ensure proper operation of the pump, fill the tank with water until the pump activates. Be certain that the water discharges properly and check for any leaks or kinks in the discharge tubing.
- Test the high level safety switch (if included with your pump, see page 4) by unplugging or disconnecting power to the pump. Start the appliance (air conditioner, furnace, etc) so it is operational. While the appliance is running, pour water into the tank reservoir. Pour slowly as to not overflow the tank. As the water rises past the main float, the safety switch should activate and break (open) the circuit to the appliance or activate (close) the switch if you have it wired to an alarm or relay. Re-connect the pump to power and allow the tank to empty. As the water level lowers, the appliance/alarm will reset.
- An alternate method for testing the safety switch is to check for continuity between the 2 wire leads with a multi-meter. If using the NO terminal to shut off a condensing unit, furnace or thermostat, there should be continuity between the wires when the tank is empty of water and the safety switch float is in the down position. If using the NC terminal to activate an alarm or relay, there should be no continuity when the tank is empty. and the safety switch float is in the down position
- Make any necessary adjustments to the pump and/or wiring at this time to ensure proper operation.

Performances

Height, tubing inner diameter and tubing length will reduce the pump output performance. It is recommended to use 3/8" ID tubing for optimum performance.

Model	GPH @ Discharge Height				
	0'	5'	10'	15'	20'
1/50 HP Models	88	84	66	6	0
1/30 HP Models	108	102	78	54	15

Maintenance

⚠ CAUTION Perform maintenance only when the pump will not be required for service. Disconnect and lockout the power source before performing any maintenance. Maintenance should be performed every 4-6 months or more frequently in heavy use applications.

1. Disconnect pump from the power source
2. Remove the upper housing from the tank by gently pulling outward and lifting up on the 4 release tabs that secure the housing to the tank.
3. Inspect the tank and internal pump parts for accumulated rust, dirt or sludge. Clean if necessary. Only use water and mild detergents to clean the pump. Do not use solvent based cleaners on any part of the pump.
4. Check the float ball to ensure it moves up and down freely. Clean if necessary.
5. If equipped with a safety switch, inspect for accumulated rust, dirt or sludge on the float. Clean if necessary. Make sure safety switch operates properly.
6. Check the drain pipe/tube from the appliance to make sure there is no build up of sludge or rust. Clean or replace if necessary.
7. Remove the discharge tubing from the barb fitting on the pump. Unthread the fitting and remove the check valve ball. See Figure 10. Backflush the fitting with water to clean. This should be performed over a pail or screen to make sure the check valve ball is not misplaced or lost. Re-attach the fitting to the pump by reversing above steps. Do not over tighten, hand tighten only.
8. Inspect discharge tubing for build up of sludge, rust or dirt. Clean or replace if necessary.
9. Check discharge line to make sure it's secured in place. Check for kinks that would decrease flow. Repair if necessary.
10. Check the motor cover for accumulated dust or debris. Clean if necessary. To remove the motor cover, remove the screw that secures the cover to the upper housing. Gently slide the cover towards the discharge fitting to release it from the locking tabs. Lift the cover off. To re-attach, reverse above steps.
11. Re-assemble the upper housing to the tank. Line up the tabs on the housing to the slots on the tank and gently push until the housing snaps into place.
12. Reconnect the pump to power.
13. Fill the pump with clean water and check for proper operation.

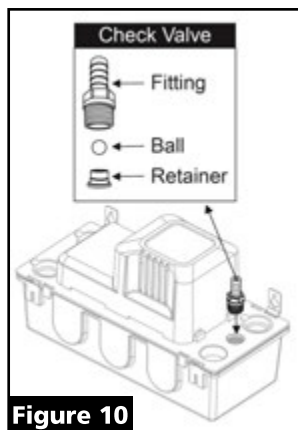

Figure 10

NOTICE!

If the pump seldomly activates, periodically pour water into the tank to test for proper operation.

Troubleshooting

PROBLEM	POSSIBLE CAUSES	HOW TO CORRECT
If the pump does not start or run	Pump is not plugged in/connected to power	Connect pump to proper power supply
	Blown fuse, tripped circuit breaker or tripped GFCI outlet	Replace fuse, reset breaker, reset GFCI outlet. Test outlet for power
	Motor thermal protector tripped	Allow pump to cool. Pump will automatically reset
	Obstructed float ball.	Check float ball for proper operation, remove obstruction or debris
	Build up of sludge, dirt or rust on float ball	Clean float ball
	Plug may not be making contact with the receptacle	Check receptacle for excess wear, replace if necessary
	Pump is not level	Make sure pump is level
	Worn or defective switch	Replace switch or pump
If the pump runs but moves little or no water	Worn or defective motor	Replace pump
	Check valve stuck, closed or plugged	Clean and inspect for proper operation
	Discharge tubing is clogged, obstructed or kinked	Check for built up rust or sludge in the tubing. Remove clog, obstruction or kink. Replace tubing if necessary
	Discharge tubing is frozen	If the discharge line is located in a freezing environment, check for frozen tubing. Move discharge line to prevent freezing
	Impeller obstructed or jammed	Check impeller, remove obstruction/debris
	Worn, damaged or clogged pump parts	Inspect for wear, damage or clog and clean or replace if necessary
Condensate overflows from the tank	Discharge head exceeds pump capacity	See page 7 for the pump's maximum lift rating. There will be no flow at the maximum lift of the pump
	Pump is not connected to power supply, tripped breaker or GFCI outlet	Connect to proper power supply. Reset breaker or GFCI outlet
	Inflow exceeds capacity of the pump.	Higher capacity pump required. If included with your pump, check the high level safety switch for proper connection to your system. The high level switch should shut down the appliance in an overflow situation
	Pump is not level	Check to ensure pump is level. A pump that is not level may not activate. Ensure the pump is on a flat and level surface. If wall mounted, ensure pump is level, adjust if necessary
	Build up on float ball	Clean float ball. A float ball with build up could be too heavy to operate
	Obstructed impeller	Check impeller housing/volute for obstructions. Clean if necessary
	Worn or defective switch	Replace switch or pump
Pump will not shut off	Inflow exceeds capacity of the pump.	Higher capacity pump required. If included with your pump, check the high level safety switch for proper connection to your system. The high level switch should shut down the appliance in an overflow situation.
	Float ball is obstructed or stuck in the on position	Check to make sure the float can move up and down freely
	Worn or defective switch	Replace switch or pump

Replacement Parts

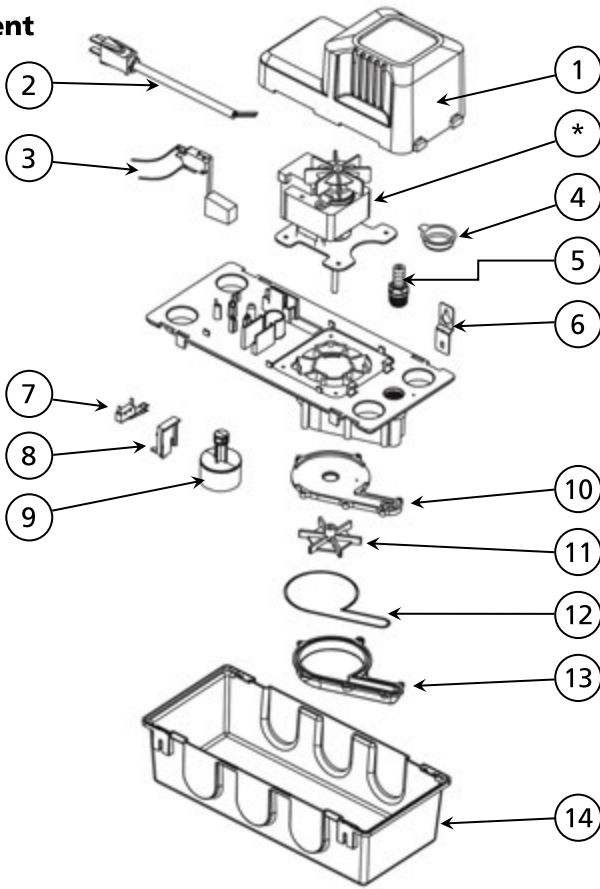

Ref#	Description	Part #
1	Motor cover	99720
2	Power cord 115 volt models	99721
3	High water safety switch w/lead wires**	99722
4	Inlet Plug	99724
5	3/8" BARB Fitting/Check Valve	99725
6	Wall mount clip	99726
7	Micro switch	99727
8	Micro switch holder	99728
9	Float ball	99729
10	Volute cover	99730
11	Impeller	99731
12	Gasket	99732
13	Volute	99733
14	Tank	99734

*If motor fails, replace entire pump

**Included with certain models only. See specifications on page 4.

LIMITED WARRANTY - UTILITY PUMPS:

Manufacturer warrants the products specified in this warranty to be free from defects in material or workmanship for three (3) years from date of purchase. During the time period and subject to the terms and conditions, Manufacturer will repair or replace to the original user or consumer any portion of this product which proves to be defective due to materials or workmanship. At all times Manufacturer shall have and possess the sole right and option to determine whether to repair or replace defective equipment, parts, or components. Manufacturer has the option to inspect any product returned under warranty to confirm that the warranty applies before repair or replacement under warranty is approved. This warranty sets forth Manufacturer's sole obligation and purchaser's exclusive remedy for defective product. For warranty consideration, call 1-800-495-9278.

WARRANTY PERIOD - PRODUCTS:

If, within the duration of product use by the original user, this product proves to be defective due to materials or workmanship, the product shall be repaired or replaced at Manufacturer's option, subject to the terms and conditions set forth in this warranty statement. Proof of purchase is required for warranty consideration. In the absence of suitable proof of the purchase date, the effective period of this warranty is 12 months from the product's date of manufacture.

LABOR, ETC. COSTS:

Manufacturer shall IN NO EVENT be responsible or liable for the cost of field labor or other charges incurred by any customer in removing and/or affixing any product, part, or component thereof.

PRODUCT IMPROVEMENTS:

Manufacturer reserves the right to change or improve its products or any portions thereof without being obligated to provide such a change or improvement for units sold and/or shipped prior to such change or improvement.

GENERAL TERMS AND CONDITIONS:

This warranty shall not apply to damage due to acts of God, normal wear and tear, normal maintenance services and the parts used in connection with such service, lightning or conditions beyond the control of Manufacturer, nor shall it apply to products which, in the sole judgment of Manufacturer, have been subject to negligence, abuse, accident, misapplication, tampering, alteration; nor due to improper installation, operation, maintenance or storage; nor to excess of recommended maximums as set forth in the instructions. Warranty will be VOID if any of the following conditions are found:

1. Product is used for purposes other than those for which it was designed and manufactured
2. Product not installed in accordance with applicable codes, ordinances, and good trade practices
3. Product connected to voltage other than indicated on nameplate or labels
4. Pump exposed to but not limited to the following: sand, gravel, cement, grease, plaster, mud, tar, oil, gasoline, solvents or other abrasive or corrosive substances
5. Pump has been used for pumping liquids above 140°F (60°C)

DISCLAIMER:

Any oral statements about the product made by the seller, Manufacturer, the representatives, or any other parties do not constitute warranties, shall not be relied upon by the user, and are not part of the contract for sale. Seller's and Manufacturer's only obligation, and buyer's only remedy, shall be the replacement and/or repair by Manufacturer of the product as described above. NEITHER SELLER NOR MANUFACTURER SHALL BE LIABLE FOR ANY INJURY, LOSS OR DAMAGE, DIRECT, INCIDENTAL OR CONSEQUENTIAL (INCLUDING, BUT NOT LIMITED TO, INCIDENTAL OR CONSEQUENTIAL DAMAGES FOR LOST PROFITS, LOST SALES, INJURY TO PERSON OR PROPERTY, OR ANY OTHER INCIDENTAL OR CONSEQUENTIAL LOSS), ARISING OUT OF THE USE OR THE INABILITY TO USE THE PRODUCT, AND THE USER AGREES THAT NO OTHER REMEDY SHALL BE AVAILABLE TO IT. Before using, the user shall determine the suitability of the product for his/her intended use, and user assumes all risk and liability whatsoever in connection therewith.

THE WARRANTY AND REMEDY DESCRIBED IN THIS LIMITED WARRANTY IS AN EXCLUSIVE WARRANTY AND REMEDY AND IS IN LIEU OF ANY OTHER WARRANTY OR REMEDY, EXPRESSED OR IMPLIED, WHICH OTHER WARRANTIES AND REMEDIES ARE HEREBY EXPRESSLY EXCLUDED, INCLUDING BUT NOT LIMITED TO ANY IMPLIED WARRANTY OF MERCHANTABILITY OR FITNESS FOR A PARTICULAR PURPOSE, TO THE EXTENT EITHER APPLIES TO A PRODUCT SHALL BE LIMITED IN DURATION TO THE PERIODS OF THE EXPRESSED WARRANTIES GIVEN ABOVE.

Some states and countries do not allow the exclusion or limitations on how long an implied warranty lasts or the exclusion or limitation of incidental or consequential damages, so the above exclusion or limitations may not apply to you. This warranty gives you specific legal rights, and you may also have other rights which vary from state to state.



mainlinecollection.com