

MultiBox™, Washing Machine Outlet Box System with Quarter Turn Valves with Hammer Arresters



Product Specifications

Product Features:

- Furnish and install single MultiBox™ Washing Machine Outlet Box
- Unit shall be MAINLINE® product code checked below, as manufactured by IPS Corporation

Box/Frame Material:

- PVC



Valve:

- Qtr. Turn Arrester Valves with Sweat, CPVC, PEX or Wirsbo connection as checked below
- Valves comply with ASME A112.18.1/CSA B125.1-05
- Arresters comply with ASSE 1010

Available Accessories:

- 3 Universal Faceplates: Open, Solid and Louvered
- Stabilizer Bar

Certifications:

- Box 
- Valve 



| To Submit | Product Code # | Product Description | Model # | Units/Case |
|-----------|----------------|--|-------------|------------|
| | ML82902 | WMOB, Qtr-turn Arrester Valves, 1/2" Sweat Connection, CP | MBS1200HACP | 10 |
| | ML82903 | WMOB, Qtr-turn Arrester Valves, 1/2" CPVC Connection, CP | MBS1201HACP | 10 |
| | ML82904 | WMOB, Qtr-turn Arrester Valves, 1/2" PEX Connection, CP | MBS1202HACP | 10 |
| | ML82905 | WMOB, Qtr-turn Arrester Valves, 1/2" Wirsbo Connection, CP | MBS1211HACP | 10 |

Warranty

See warranty information for more details.

All dimensions listed are nominal. MAINLINE® reserves the right to make product and material changes at any time without notice.

Contact your sales representative for more information or visit our website at mainlinecollection.ca

MultiBox™, Washing Machine Outlet Box System with Quarter Turn Valves with Hammer Arresters

Product Specifications

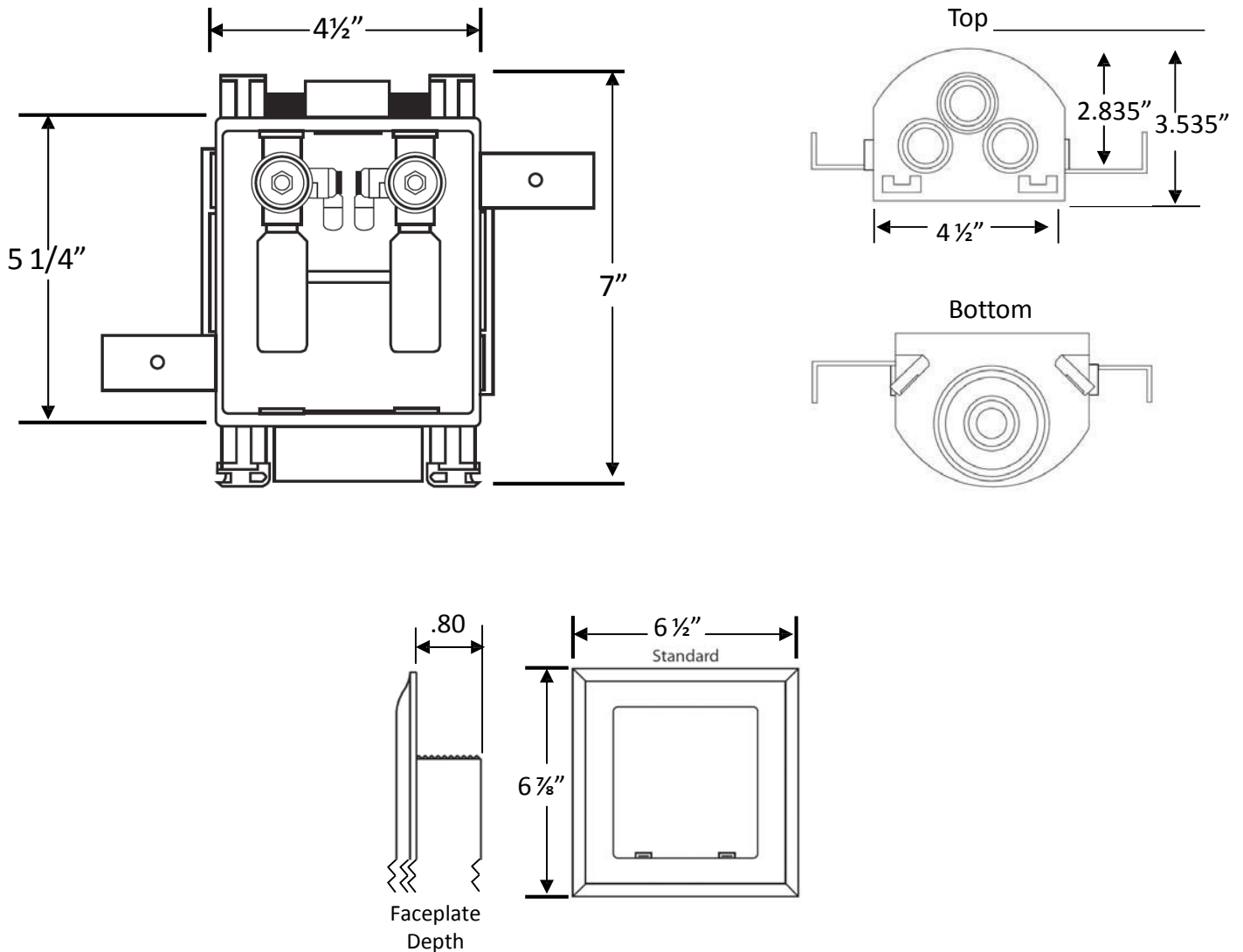

Warranty

See warranty information for more details.

All dimensions listed are nominal. MAINLINE® reserves the right to make product and material changes at any time without notice.

Contact your sales representative for more information or visit our website at mainlinecollection.ca